

HYDRAULIC CLAMP HCS

The HCS has a high clamping force regarding to its small size.

Advantage:

- High clamping capacity
- Replace manual bolts
- Does not require any space outside the die

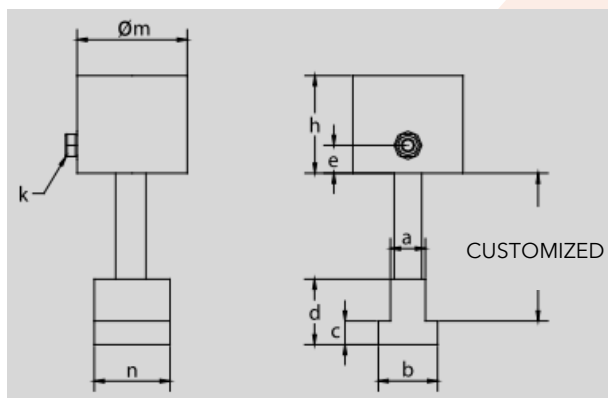
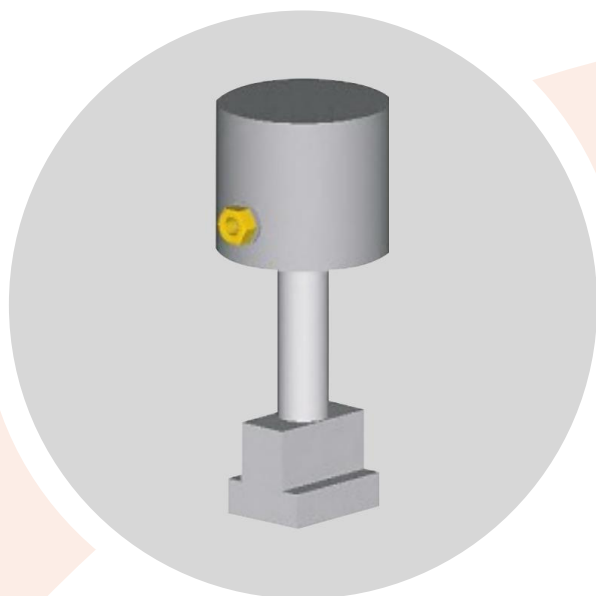

Type	Clamping force	a	b	c	d	e	h	k	m	n
HCS 10	10 kN/200 bar	17,7	28	10	20	20	45	¼"	40	28
HCS 20	20 kN/200 bar	17,7	28	10	20	14	60	¼"	65	28
HCS 40	40 kN/200 bar	21,7	35	14	28	14	60	¼"	65	35
HCS 70	70 kN/200 bar	27,7	44	18	36	14	70	¼"	80	44
HCS 100	100 kN/200 bar	35,7	54	22	44	16	92	¼"	100	54
HCS 150	150 kN/200 bar	35,7	54	22	44	16	92	¼"	120	54

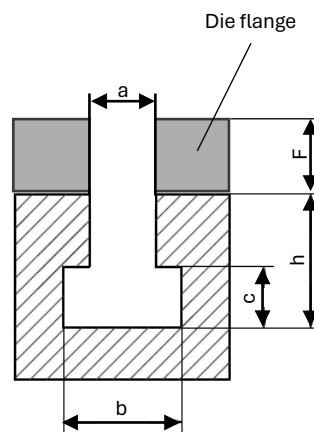

For inquiry or order

- Specify max. die weight (W)
- Specify die flange height (F)
- Measure your T-slot (a, b, c, h)

Roller type	T-slot (mm)	W (kgs)	a (mm)	b (mm)	c (mm)	F (mm)	h (mm)

HYDRAULIC CLAMP HKS

Versatile clamping unit for different die sizes

Advantage:

- High clamping capacity
- Replace manual bolts
- Requires only a small clamping area

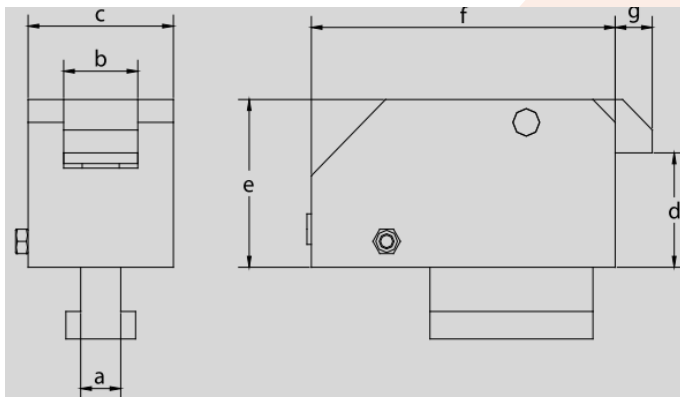
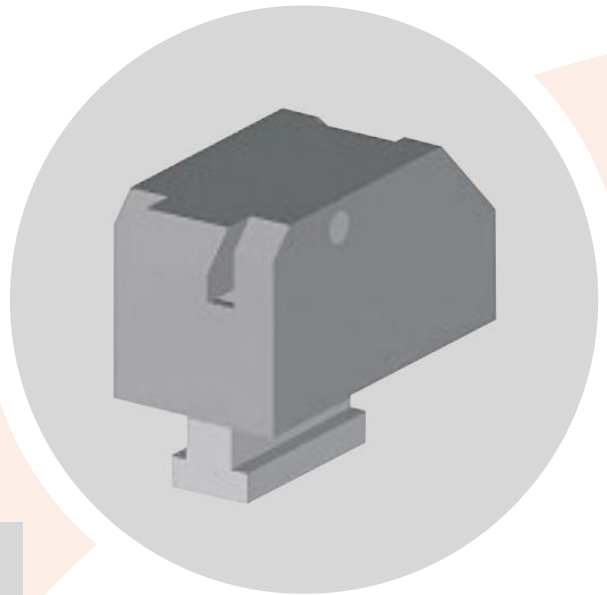

Type	Clamping force	a	b	c	d	e	f	g
HKS 8	8 kN/200 bar	17	25	58	30	65	80	20
HKS 20	20 kN/200 bar	17	35	63	40	80	116	20
HKS 40	40 kN/200 bar	21	40	78	60	97	140	20
HKS 70	70 kN/200 bar	21	50	98	75	110	155	25
HKS 100	100 kN/200 bar	27	50	98	75	110	205	25
HKS 150	150 kN/200 bar	35	50	196	75	110	205	25

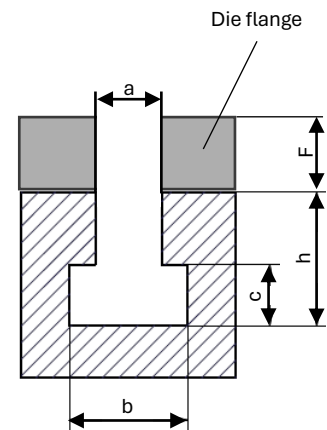

For inquiry or order

- Specify max. die weight (W)
- Specify die flange height (F)
- Measure your T-slot (a, b, c, h)

Roller type	T-slot (mm)	W (kgs)	a (mm)	b (mm)	c (mm)	F (mm)	h (mm)

HYDRAULIC CLAMP HTS

Versatile clamping unit for different die sizes

Advantage:

- High clamping capacity
- Replace manual bolts
- Does not require any milled slots in the die
- Small and compact

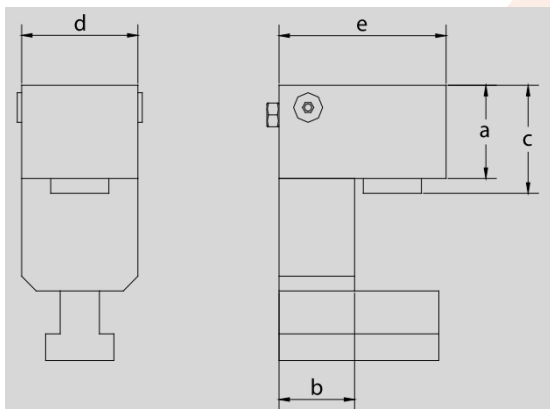
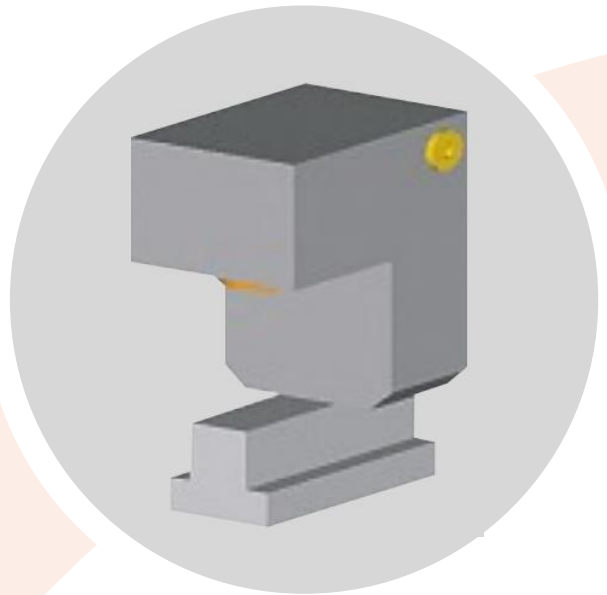

Type	Clamping force	a	b	c	d	e
HTS 20	20 kN/200 bar	63	40	64,5 – 72,5	50	80
HTS 40	40 kN/200 bar	63	46	64,5 – 72,5	63	100
HTS 56	56 kN/200 bar	63	56	81,5 – 89,5	80	115

For inquiry or order

- Specify max. die weight (W)
- Specify die flange height (F)
- Measure your T-slot (a, b, c, h)

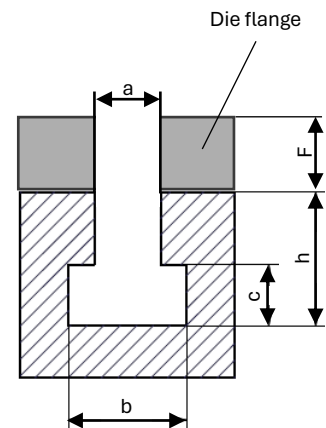

Roller type	T-slot (mm)	W (kgs)	a (mm)	b (mm)	c (mm)	F (mm)	h (mm)

HYDRAULIC CLAMP HBS

Versatile clamping unit for different die sizes

Advantage:

- Fixed to the press table and ram
- Guiding and clamping in one device

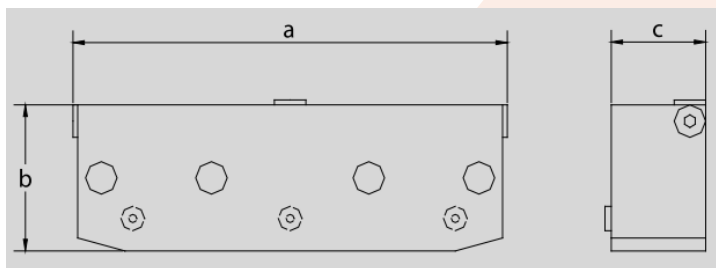
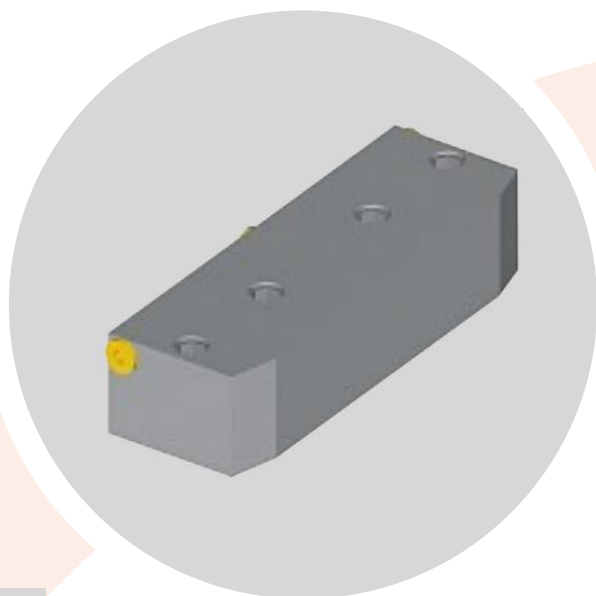

Type	Clamping force	No. of pistons	Stroke length	a	b	c
HBS 25	25 kN/200 bar	3	5 mm	270	90	45
HBS 40	40 kN/200 bar	5	5 mm	270	90	45
HBS 70	70 kN/200 bar	7	5 mm	370	90	45
HBS 100	100 kN/200 bar	10	5 mm	520	90	45

For inquiry or order

- Specify max. die weight (W)
- Specify die flange height (F)
- Measure your T-slot (a, b, c, h)

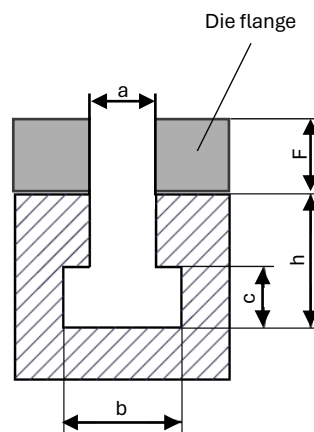

Roller type	T-slot (mm)	W (kgs)	a (mm)	b (mm)	c (mm)	F (mm)	h (mm)